

**LACUEVA CAN MAKING MACHINERY, S.L.**  
 Poligono Industrial El Roturo, parcela 1  
 26511 El Villar de Arnedo  
 La Rioja - Spain  
 VAT CODE.: ES-B-26437244



**PROFORMA INVOICE 23022**

**CUSTOMER:**

KIMIYA CHIMI DAMAVAND  
 N° 2 Ashena Alley, Mobarra Alley  
 Khayam St. Tehran 1191946363  
 IRAN

Fecha: 27-07-2023

VAT

Und.	Description	Price	TOTAL
1	<b>DOUBLE LINER OMPI WITH NEW TOOLING, NEW ELECTRIC OVEN FROM OMPI, WITH TANK AND DOUBLE STACKER</b> Manufacturing year 2018 mod. MTD 80-109 <b>HS CODE: 8422 30 00</b>  Gross weight: 5100 kg aprox. Net weight: 4800 kg aprox	70,000 €	70,000 €
1	<b>TRANSFER PRESS BMV T-4 ID.LACUEVA 23798514</b> Force 32Tn, long stroke 100mm, with spare parts for the press Manufacturing year 2018 <b>HS CODE: 8462 69 00</b> Gross weight: 7400 kg aprox. Net weight: 7000 kg aprox  <b>ORIGIN COUNTRY: ITALY</b>	10,000 €	10,000 €
<div style="border: 2px solid black; background-color: #fce4d6; padding: 5px; display: inline-block;"> <b>OUR ADDRESS:</b>            LACUEVA CAN MAKING MACHINERY, S.L.            POLIG. IND. EL ROTURO, PARCELA 1            26511 El Villar de Arnedo (La Rioja) SPAIN         </div>			
Transport cost not included			

**PAYMENT TERMS**

**100% by swift transfer at sight**

**TOTAL 80,000 €**

**BANCO:** SABADELL  
**COD.IBAN** ES-12 0081 7151 27 0001048715  
**C.SWIFT** BSABESBB

**TOTAL 80,000 €**

EXW LA RIOJA

Sale subject to our terms of sale which can be downloaded from our web site

Email: [lacueva@maquinarialacueva.com](mailto:lacueva@maquinarialacueva.com)  
 Web: [www.maquinarialacueva.com](http://www.maquinarialacueva.com)

Telf. +34 941 130918

Fax: +34 941 135113

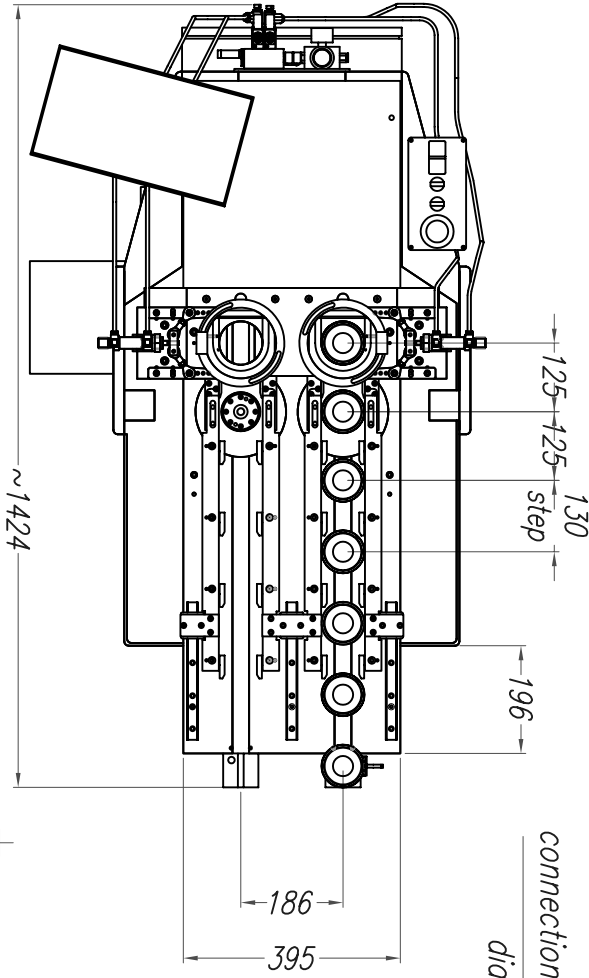
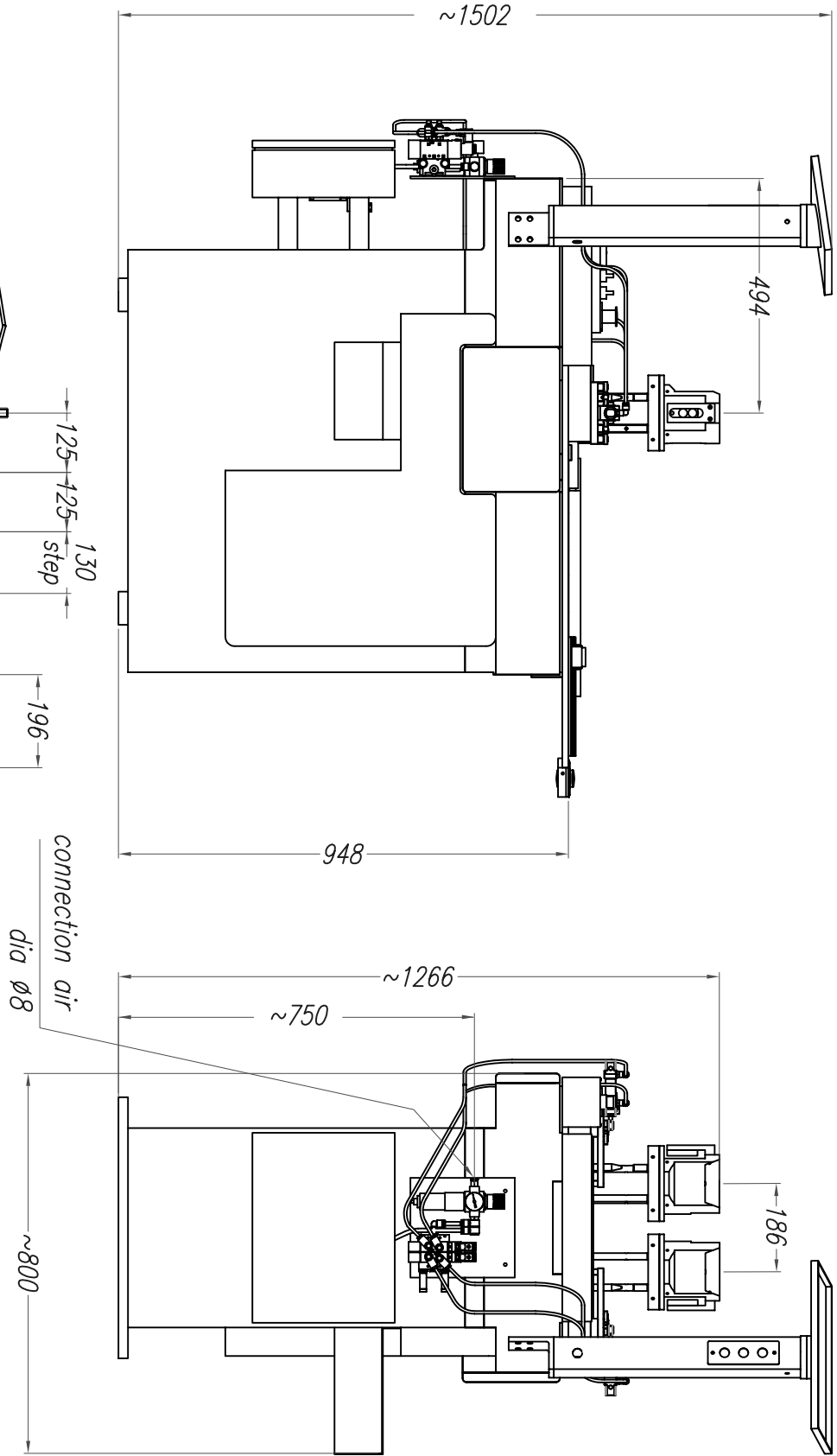

TABLE 1 of 10  
Compound Liner  
Layout

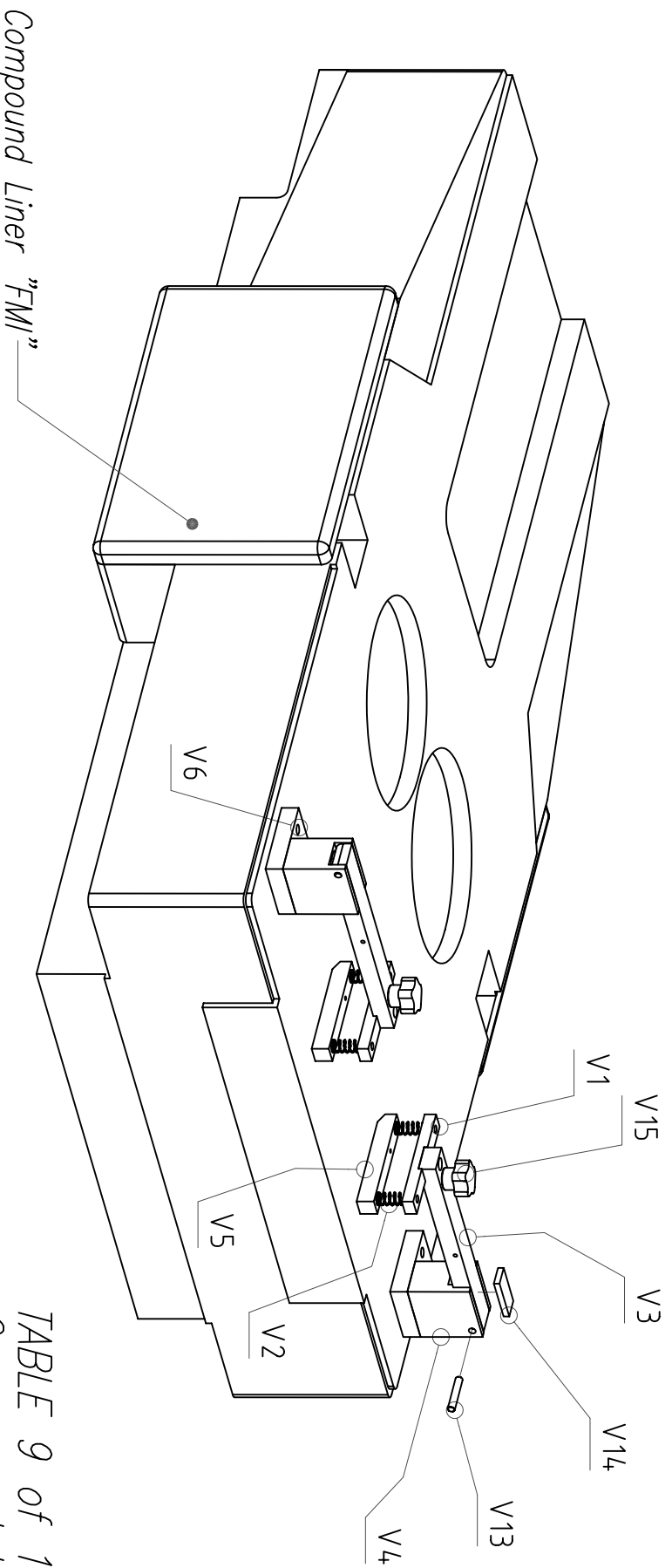

TABLE 9 of 10  
Compound Liner

Double ends jam Unit "V"

V15	2	HAND GRIP M6	ON SALE
V14	2	NEODYMIUM MAGNET 18X5X4.0	ON SALE
V13	2	PIN $\phi 6 \times 35$ h8	ON SALE
N°pos	Q ty	Name	n° drawing
ON SALE			

V6	2	BASE FOR SUPPOR	MTD-12-019A
V5	2	TOUCHING PLATE	MTD-12-014
V4	2	SUPPORT FOR BAR	MTD-12-013C
V3	2	BAR FOR DUPBLE ENDS JAM	MTD-12-012B
V2	4	SPRING	MTD-12-009
V1	2	SUPPOR FOR TOUCHING PLATE	MTD-12-006
N°pos	Q ty	Name	n° Drawing
DRAWING LIST			

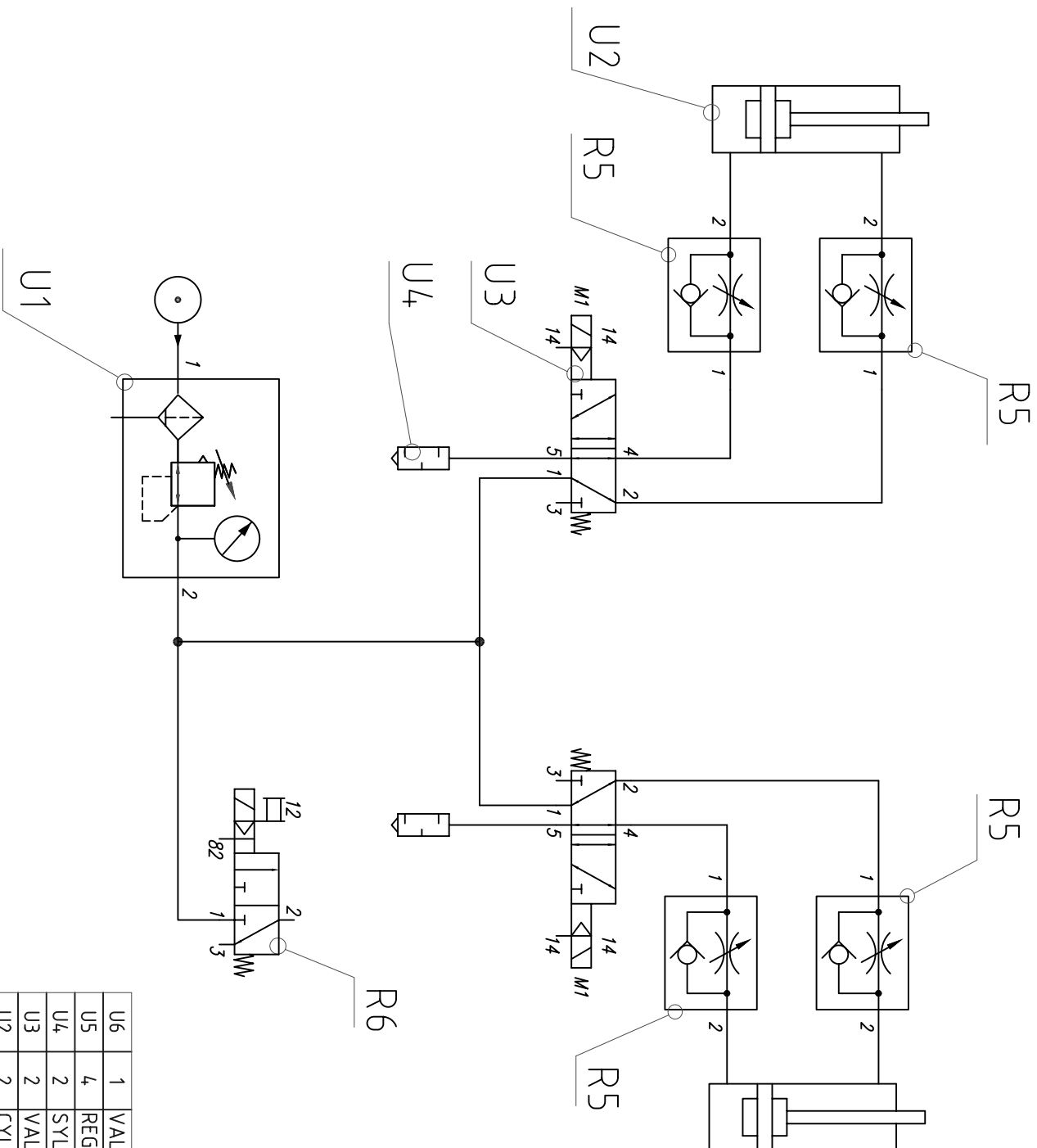
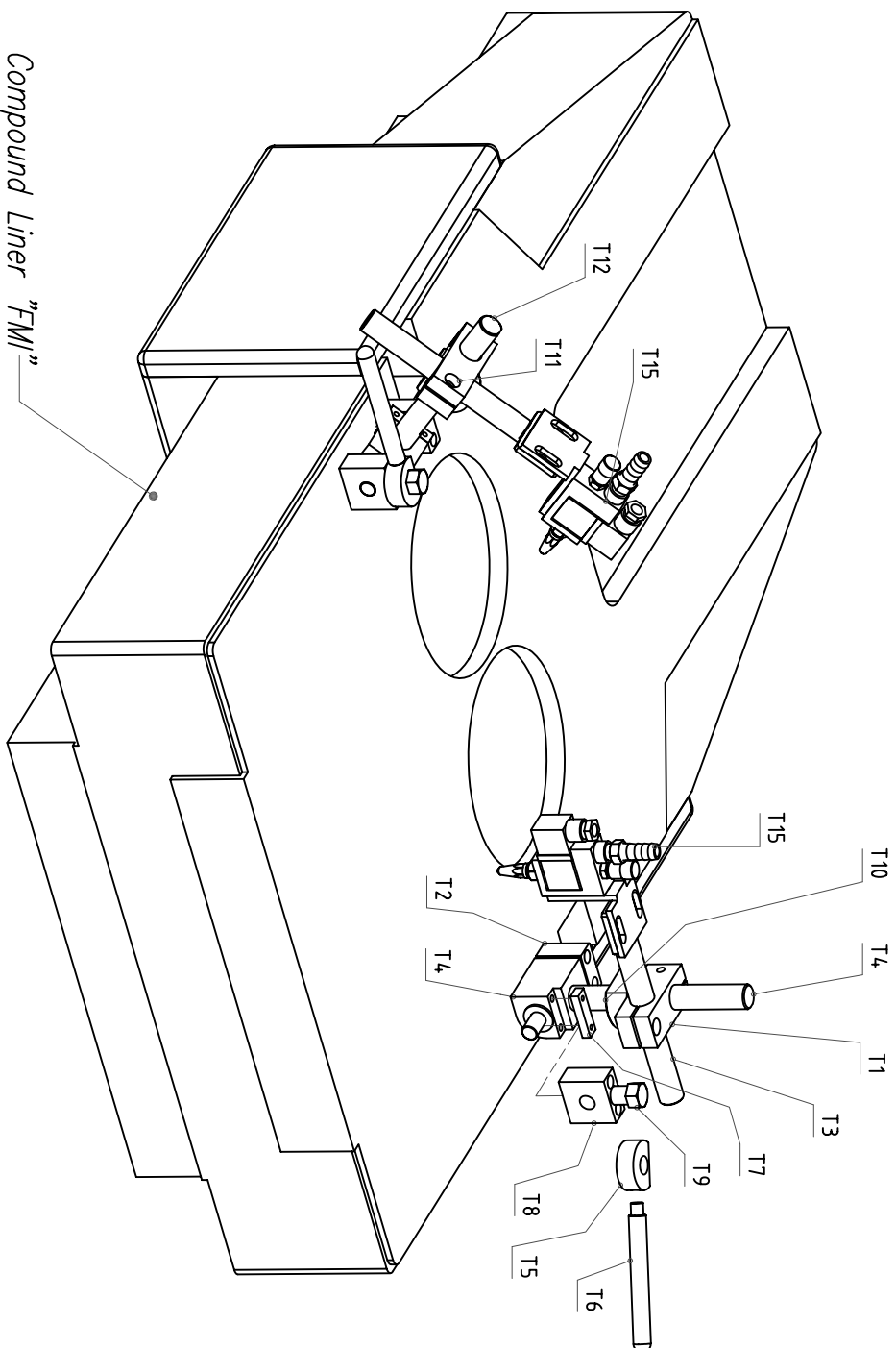

TABLE 8 of 10  
 Compound Liner  
 Pneumatic Diagram "U"

U6	1	VALVE MFH3 1/4"	ON SALE
U5	4	REGULATOR OF PRESSURE GR1A 1/8 QS-6-RS-B	ON SALE
U4	2	SYLENCER U-1/4	ON SALE
U3	2	VALVE VUVS-L20-M52-MH-G18-F7-1C1	ON SALE
U2	2	CYLINDER DSN 20-10-P	ON SALE
U1	1	REDUCTION OF PRESSURE LFR-1/4-D-MINI	ON SALE
N°pos	Q ty	Name	n° drawing
ON SALE			

TABLE 7 of 10  
 Compound Liner  
 Holder Guns Unit "7"



N°pos	Qty	Name	ON SALE	n° drawing
T15	2	ELECTROMAGNETIC GUN type "NTEGPC"	ON SALE	

T12	1	SUPPORT FOR HOLDER GUN	MTD-03-143-MR	
T11	1	HOLDING GUN HORIZONTAL SHAFT SUPPORT	MTD-03-139-MR	
T10	2	WASHER	MTD-04-098	
T9	2	PIN FOR LOCKING ARM HOLDER GUN	MTD-03-148	
T8	2	LOCKING PLATE FOR ARM HOLDER GUN	MTD-03-147	
T7	2	LOCKING PLATE	MTD-03-146	
T6	2	LOCKING LEVER	MTD-03-145	
T5	2	PLATE FOR LOCKING ARM HOLDER GUN	MTD-03-144	
T4	1	SUPPORT FOR HOLDER GUN	MTD-03-143	
T3	2	HOLDING GUN HORIZONTAL SHAFT	MTD-03-142	
T2	2	LOCKING PLATE FOR HOLDER GUN	MTD-03-140	
T1	2	HOLDING GUN HORIZONTAL SHAFT SUPPORT	MTD-03-139	

DRAWING LIST

Name n° Drawing

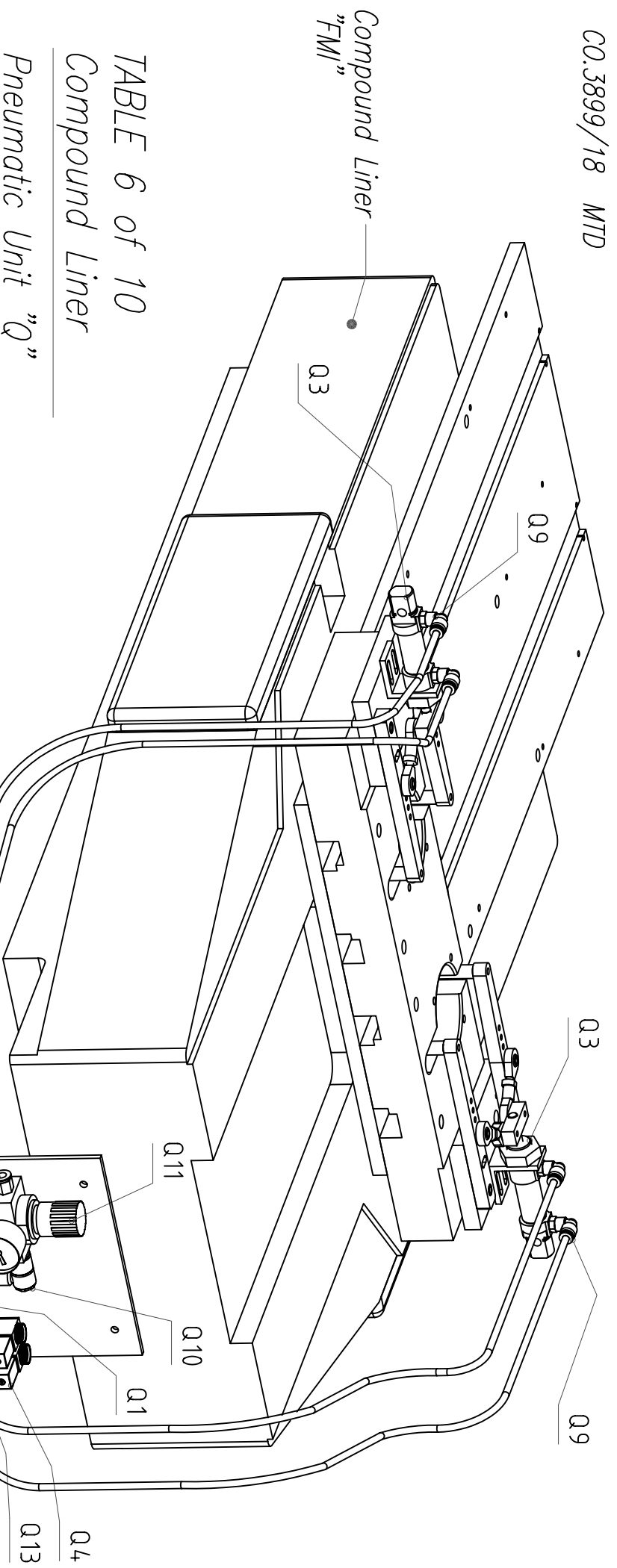

TABLE 6 of 10  
Compound Liner

Pneumatic Unit "Q"

Q13	2	SYLENCER U-1/4	ON SALE
Q12	4	FLUX-REGULATOR GRLA 1/8 QS-6-RS-B	ON SALE
Q11	1	FILTER LFR-1/4-D-Mini	ON SALE
Q10	1	CONNECTION QSLV-2-1/4-8	ON SALE
Q9	4	CONNECTION QSL-1/8-6	ON SALE
Q8	2	CONNECTION QSL 1/4-8	ON SALE
Q7	1	CONNECTION QS-1/4-8	ON SALE
Q6	1	VALVE MFH3 1/4"	ON SALE
Q5	2	VALVE VUVS-L20-M52-MH-G18-F7-1C1	ON SALE
Q4	2	CONNECTOR MSSD-EB	ON SALE
Q3	2	CYLINDER DSN 20-10 P	ON SALE
Q2	1	COIL MSFG 24/42 50/60	ON SALE
Q1	1	VABM-B10-20S-G14-2	ON SALE
N°pos	Q ty	Name	n° drawing
		ON SALE	

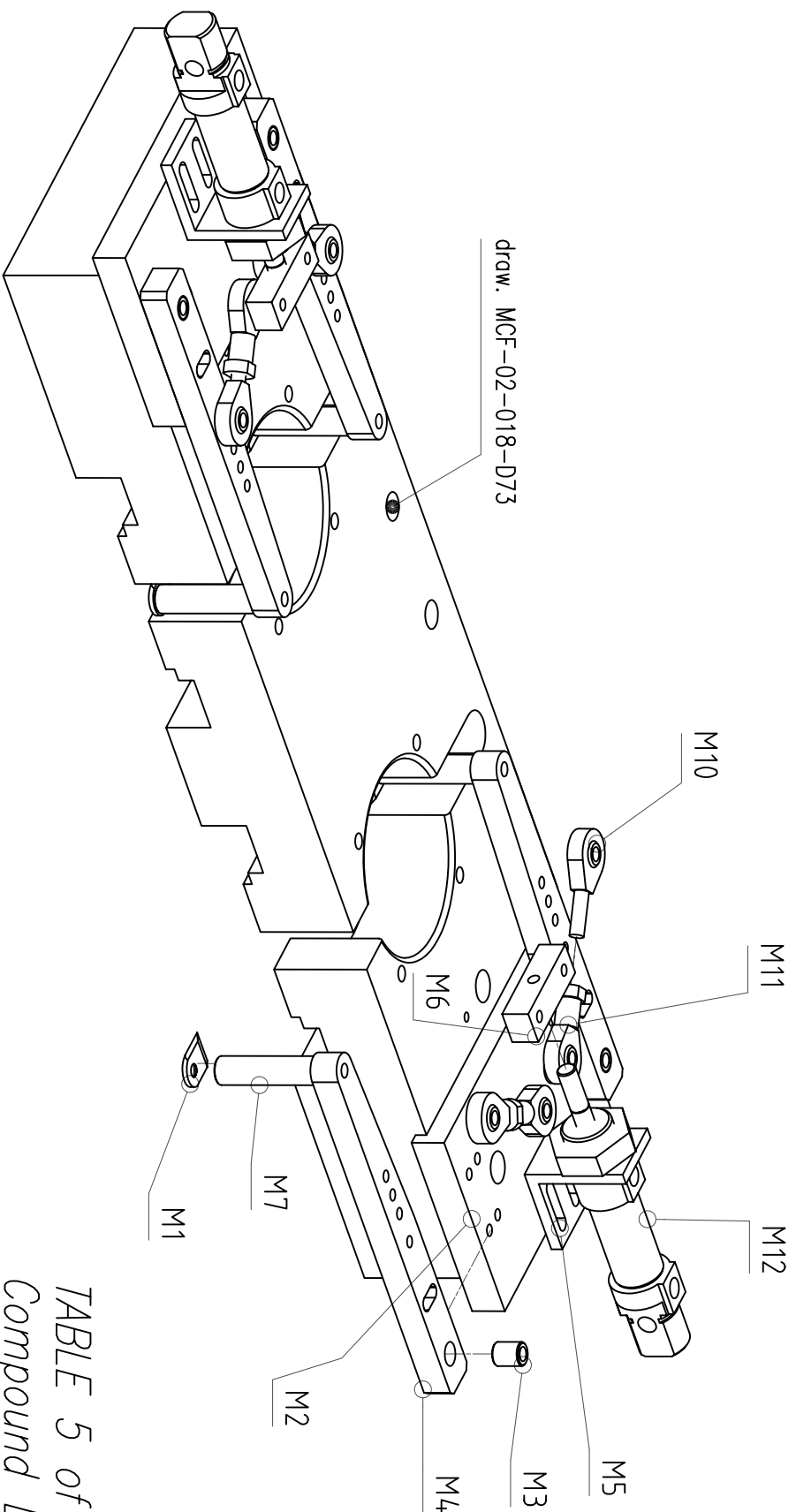

TABLE 5 of 10  
 Compound Liner  
 TOP Stacker DIA 73 "M"

M12	2	CYLINDER DSN 20-10 P	ON SALE
M11	4	SIKAC M6	ON SALE
M10	4	SAKAC M6	ON SALE
N.Pos.	Q.ty	Name	n° drawing

DRAWING LIST

M7	4	SPACER	MTD-02-276
M6	2	SUPPORT FOR BEARING	MTD-02-047B
M5	2	SUPPORT FOR CYLINDER	MTD-02-046A
M4	4	ROD	MTD-02-042A
M3	4	BUCKLE	MTD-02-041
M2	2	BASE	MTD-02-040G
M1	4	BLADE	MTD-02-035
N.Pos.	Q.ty	Name	N° Drawing

DRAWING LIST

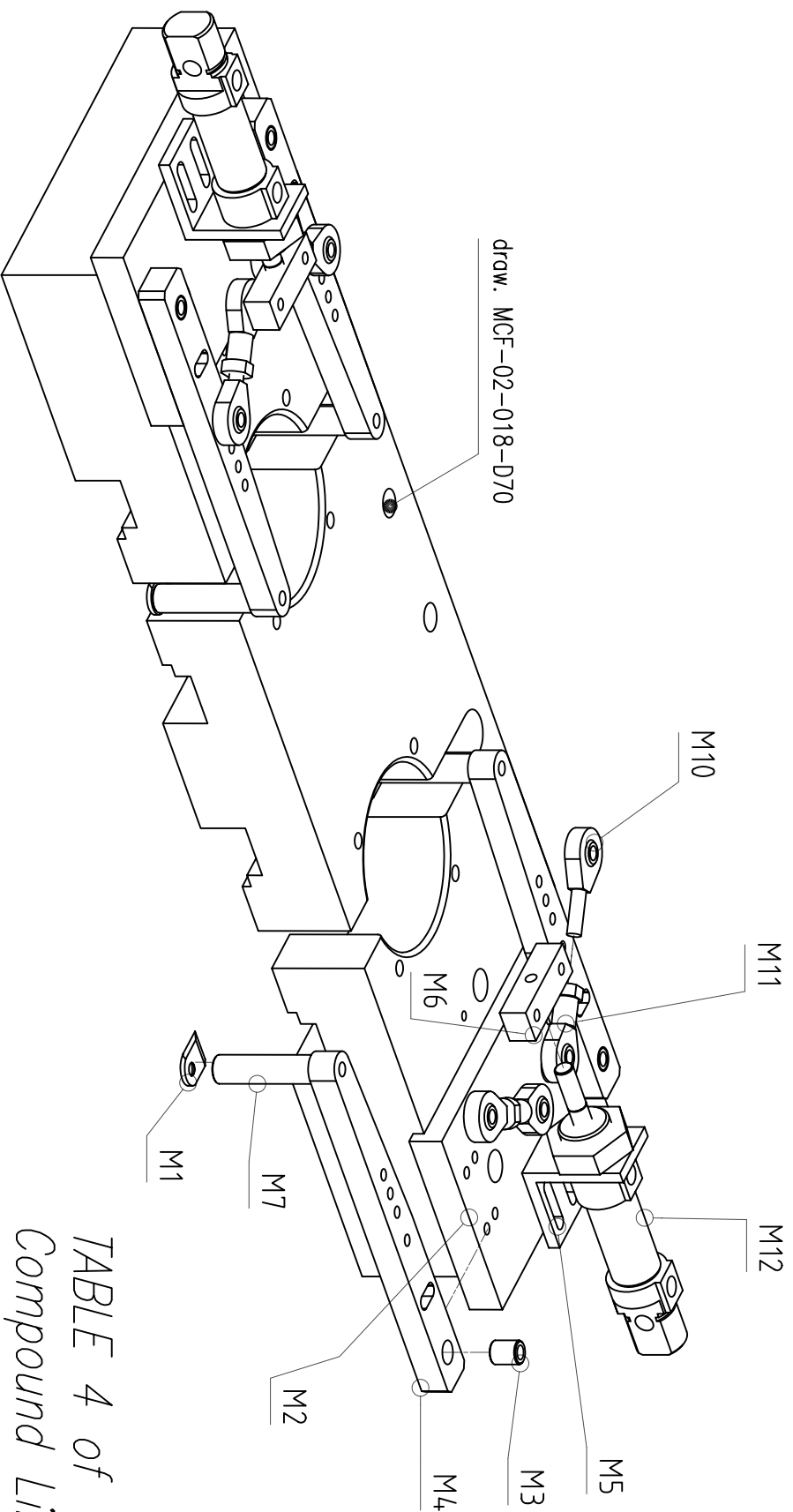

TABLE 4 of 10  
 Compound Liner  
 TOP Stacker DIA 70 "M"

M12	2	CYLINDER DSN 20-10 P	ON SALE
M11	4	SIKAC M6	ON SALE
M10	4	SAKAC M6	ON SALE
N.Pos.	Q.ty	Name	N° Drawing
ON SALE			

M7	4	SPACER	MTD-02-276
M6	2	SUPPORT FOR BEARING	MTD-02-047B
M5	2	SUPPORT FOR CYLINDER	MTD-02-046A
M4	4	ROD	MTD-02-042A
M3	4	BUCKLE	MTD-02-041
M2	2	BASE	MTD-02-040G
M1	4	BLADE	MTD-02-035
N.Pos.	Q.ty	Name	N° Drawing
DRAWING LIST			



TABLE 3 of 10  
Compound Liner  
Tooling Unit DIA 73 "L"

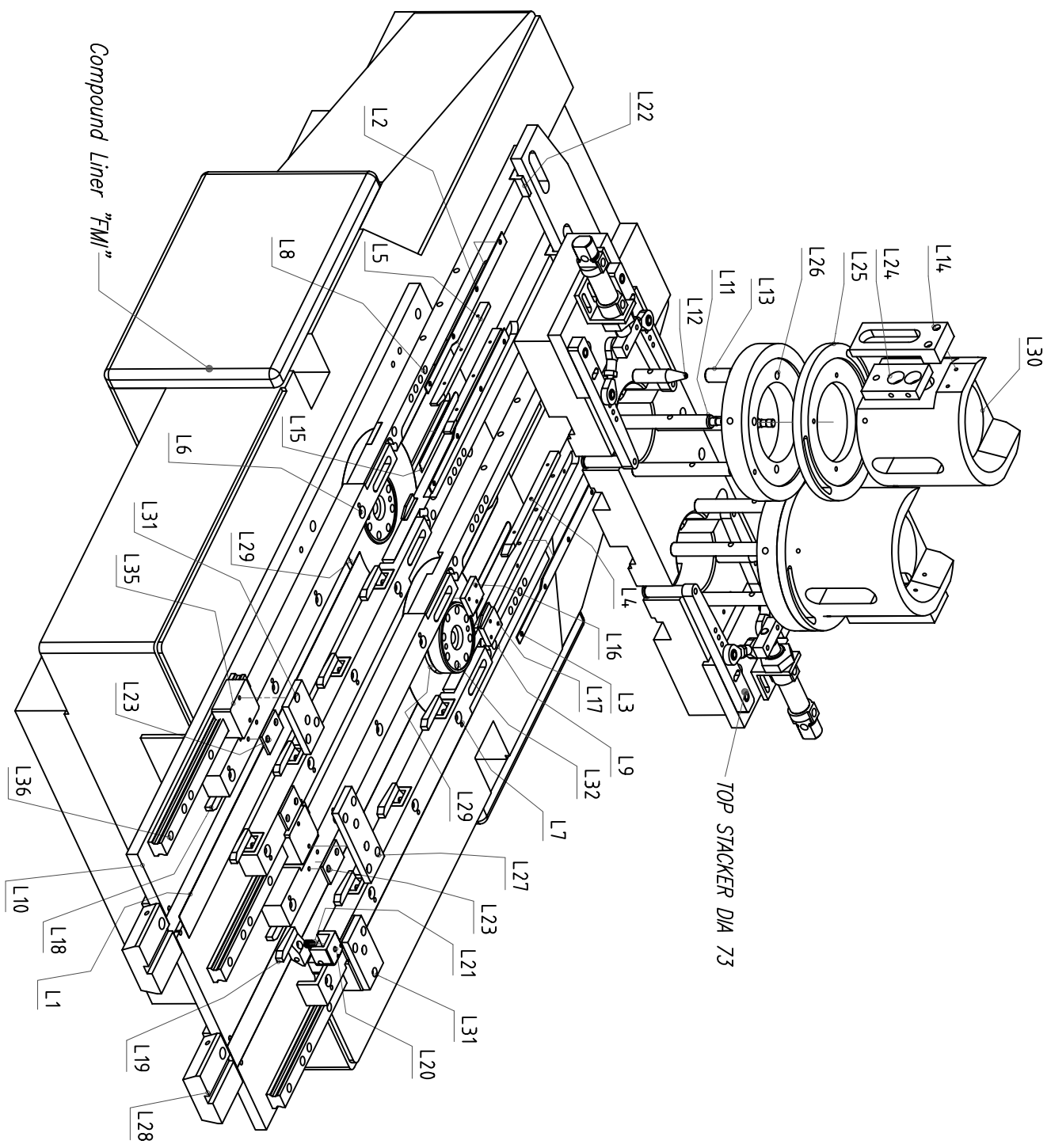

L36	3	RAIL "THK" SR20-250L E20 (GK)	MTD-03-377
L35	3	BLOCK "THK" SSR20-XV1SS (GR)	MTD-03-378
N°Pos./Qty		Name	N° Drawing
		ON SALE	

L32	2	CHUCK	MTD-04-001H
L31	2	SUPPORT FOR TROLLEY	MTD-03-374A
L30	2	ENDS ENTRY UNIT	MTD-02-021A-D73
L29	2	RING	MCF-03-261
L28	2	LINKING PLANE	MCF-03-024
L27	1	CENTRAL SUPPORT FOR TROLLEY	MCF-03-004-E81.7
L26	2	INFERIOR RING	MCF-02-107-D73
L25	2	ADJUSTMENT RING	MCF-02-106-D73
L24	2	SUPPORT FOR DOUBLE SENSOR	MTD-02-338
L23	4	SPACER	MTD-03-375B
L22	4	THICKNESS	MTD-03-241
L21	16	FINGER SPRING cod. 1-MC497	MTD-03-211
L20	16	HOLDING FINGER	MTD-03-052
L19	8	FINGER	MTD-03-044A02-MR
L18	8	FINGER	MTD-03-044A02
L17	2	END MOTION FINGER	MTD-03-0385-MR
L16	2	END MOTION FINGER	MTD-03-0385
L15	4	COVER PLATE	MTD-02-340
L14	2	HINGE SENSOR STACKER	MTD-02-022
L13	2	IN PILE UPPER PICKER ROD	MTD-02-020D
L12	2	IN PILE LOWER PICKER ROD	MTD-02-020C03
L11	6	IN PILE PICKER ROD	MTD-02-020-116
L10	1	UPPER PLATE	MCF-03-281
L9	2	CONVEYOR	MCF-03-103-MR
L8	2	CONVEYOR	MCF-03-103
L7	2	CONVEYOR EXTENSION	MCF-03-042-MR
L6	2	CONVEYOR EXTENSION	MCF-03-042
L5	2	BAR FOR CONVEYOR	MCF-03-002-MR
L4	2	BAR FOR CONVEYOR	MCF-03-002
L3	2	HOLDING ENDS BLADE	MCF-03-001-MR
L2	2	HOLDING ENDS BLADE	MCF-03-001
L1	2	PLATE	MCF-02-135
N°Pos./Qty		Name	N° Drawing

DRAWING LIST

TABLE 2 of 10  
Compound Liner  
Tooling Unit DIA 70 "L"

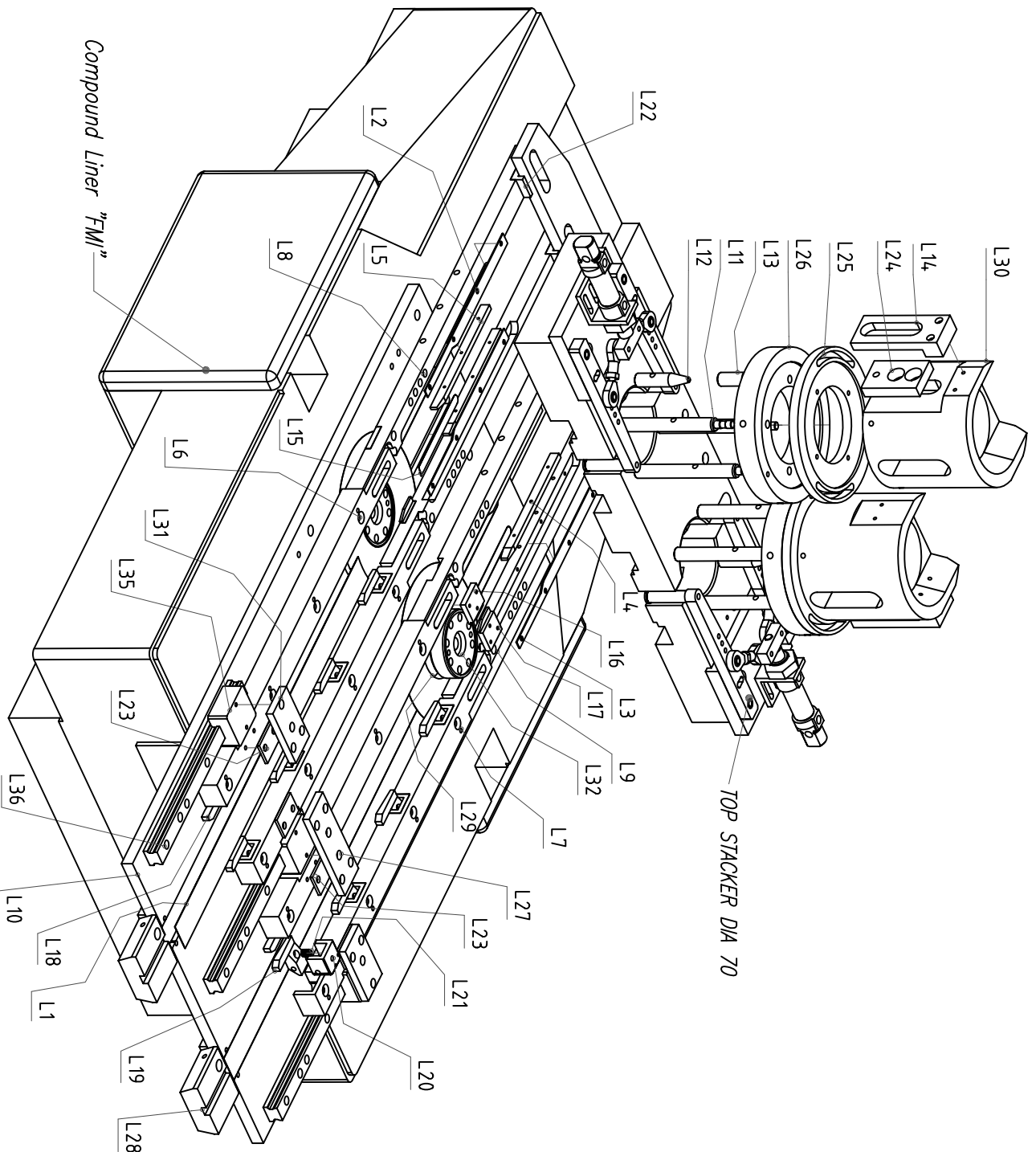

L36	3	RAIL "THK" SR20-250L E20 (GR)	MTD-03-377
L35	3	BLOCK "THK" SSR20-XV15S (GR)	MTD-03-378
N°Pos	Qty	Name	N° Drawing
ON SALE			

L32	2	CHUCK	MTD-04-001H
L31	2	SUPPORT FOR TROLLEY	MTD-03-374C
L30	2	ENDS ENTRY UNIT	MTD-03-021A
L29	2	RING	MCF-03-261
L28	2	LINKING PLANE	MCF-03-024
L27	1	CENTRAL SUPPORT FOR TROLLEY	MCF-03-004-E78.1
L26	2	INFERIOR RING	MCF-02-107-D70
L25	2	ADJUSTMENT RING	MCF-02-106-D70
L24	2	SUPPORT FOR DOUBLE SENSOR	MTD-02-338
L23	4	SPACER	MTD-03-375B
L22	4	THICKNESS	MTD-03-241
L21	16	FINGER SPRING cod. 1-MC497	MTD-03-211
L20	16	HOLDING FINGER	MTD-03-052
L19	8	FINGER	MTD-03-044A02-MR
L18	8	FINGER	MTD-03-044A02
L17	2	END MOTION FINGER	MTD-03-0385-MR
L16	2	END MOTION FINGER	MTD-03-0385
L15	4	COVER PLATE	MTD-02-340
L14	2	HINGE SENSOR STACKER	MTD-02-022
L13	2	IN PILE UPPER PICKER ROD	MTD-02-020D
L12	2	IN PILE LOWER PICKER ROD	MTD-02-020C03
L11	6	IN PILE PICKER ROD	MTD-02-020-116
L10	1	UPPER PLATE	MCF-03-281
L9	2	CONVEYOR	MCF-03-103-MR
L8	2	CONVEYOR	MCF-03-103
L7	2	CONVEYOR EXTENSION	MCF-03-042-MR
L6	2	CONVEYOR EXTENSION	MCF-03-042
L5	2	BAR FOR CONVEYOR	MCF-03-002-MR
L4	2	BAR FOR CONVEYOR	MCF-03-002
L3	2	HOLDING ENDS BLADE	MCF-03-001-MR
L2	2	HOLDING ENDS BLADE	MCF-03-001
L1	2	PLATE	MCF-02-135
N°Pos	Qty	Name	N° Drawing

DRAWING LIST

TABLE 10 of 10  
Compound Liner

Magnetic Plane "Z"  
DIA 70-73

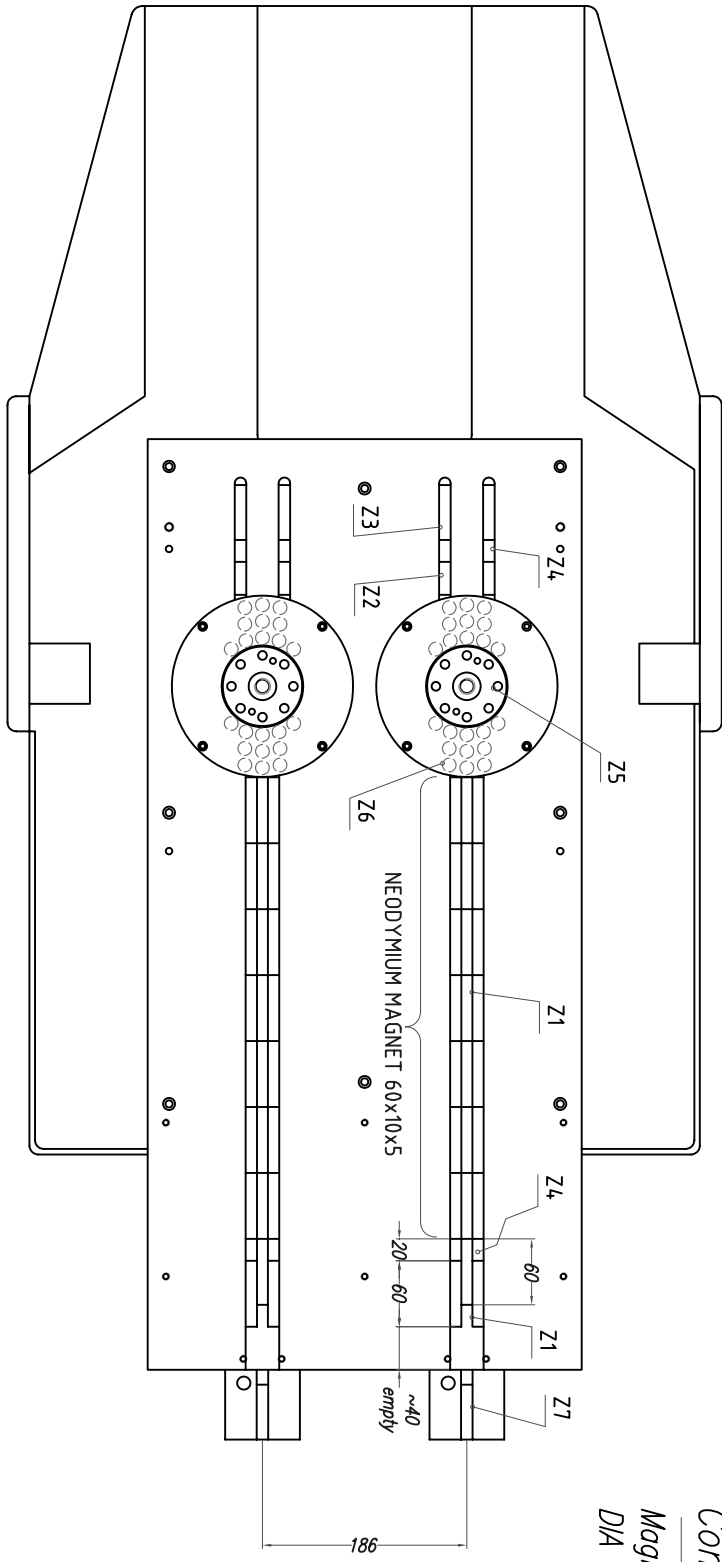

Z7	2	NEODYMIUM MAGNET 50x10x5	ON SALE
Z6	44	NEODYMIUM MAGNET $\phi$ 12X4	ON SALE
Z5	16	NEODYMIUM MAGNET $\phi$ 8x8	ON SALE
Z4	8	NEODYMIUM MAGNET 20x10x5	ON SALE
Z3	4	FERRITE MAGNET 50x10x5	ON SALE
Z2	4	FERRITE MAGNET 30x10x5	ON SALE
Z1	48	NEODYMIUM MAGNET 60x10x5	ON SALE
N°pos	Q	Ty	Name
ON SALE			
			n° drawing